

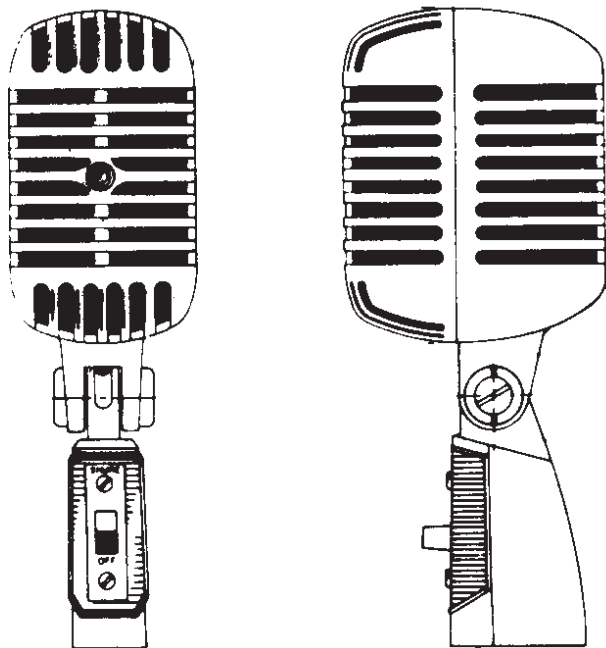

Shure Brothers Incorporated
 222 Hartrey Avenue
 Evanston IL 60202-3696 U.S.A.

Phone: 800-257-4873 Fax: 847-866-2279
 In Europe, Phone: 49-7131-72140 Fax: 49-7131-721414
 Internationally, Phone: 847-866-2200 Fax: 847-866-2585
 Web Address: <http://www.shure.com>

MODEL 55SH UNIDIRECTIONAL DYNAMIC MICROPHONE **Specification Sheet**



GENERAL

The Model 55SH Series II provides the Shure classic UNIDYNE® II design coupled with entirely new acoustic components to meet today's performance standards. This microphone is particularly excellent for vocal pickup with its characteristic Shure presence peak.

The 55SH Series II has a cardioid (unidirectional) polar pickup pattern that minimizes sound pickup from the rear of the microphone. Because of this characteristic, the Model 55SH Series II can be used closer than usual to loudspeakers without creating feedback problems and will provide very satisfactory operation under adverse acoustic conditions where an omnidirectional microphone may not function properly.

The 55SH Series II has a low-impedance balanced output designed for connection to microphone inputs rated at 75 to 300 ohms. An effective new cartridge shock mount reduces stand noise; and an On/Off switch is supplied on the attached self-tensioning swivel that mounts on a stand with a 5/8"-27 thread.

This microphone is ideal for excellent quality public address or theater-stage sound systems, as well as for broadcasting, recording, and other sound applications where a stand-mounted microphone with a classic look is desirable.

Features

- *Classic appearance, yet modern performance*
- *Frequency response effective for speech or vocal and instrumental music*
- *Cardioid directional pattern especially suited for optimum performance in adverse acoustic environments*
- *Shock-mounted cartridge minimizes stand-transmitted noise, ensures quiet operation*
- *Rugged die cast case and mechanical design for reliability under rigorous conditions*
- *Self-tensioning swivel mount, permits tilting through 45° forward and 80° backward*

SPECIFICATIONS

Type

Dynamic

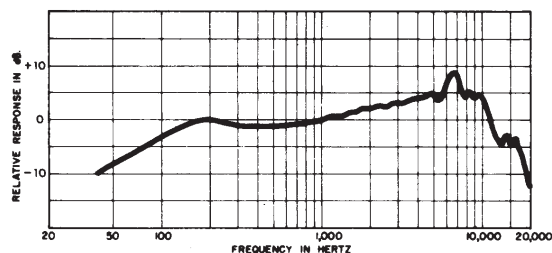

TYPICAL FREQUENCY RESPONSE
FIGURE 1

Polar Pattern

Cardioid (unidirectional), uniform with frequency, symmetrical about axis (see Figure 2)

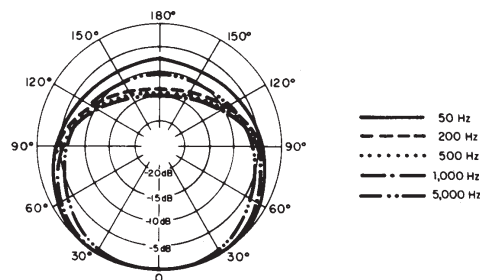

TYPICAL POLAR PATTERNS
FIGURE 2

Impedance

Microphone rating impedance is 150 ohms (270 ohm actual) for connection to microphone inputs rated at 75 to 300 ohms

Output Level (at 1,000 Hz)

Open Circuit Voltage -78.0 dB (0.13 mV)
 0 dB = 1 volt per microbar
 Power Level -58.5 dB
 0 dB = 1 milliwatt per 10 microbar

Phasing

Positive pressure on the diaphragm produces positive voltage on pin 2 relative to pin 3 of the output connector

Switch

Built-in On/Off switch, integral part of swivel mount connector Three pin professional type, designed to mate with Cannon XL series, Switchcraft A3 (Q.G.) series, or equivalent

Case

Chrome-plated die casting

Dimensions

See Figure 3

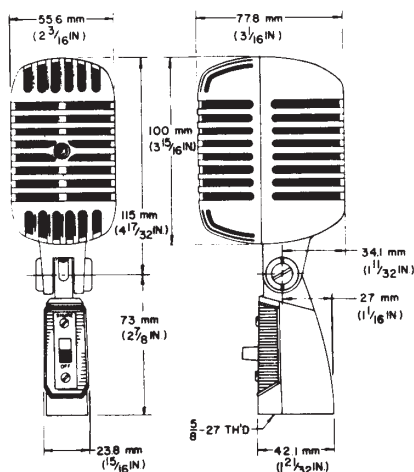

**OVERALL DIMENSIONS
 FIGURE 3**

Net Weight

625 grams (22 oz)

Certifications

Conforms to European Union directives, eligible to bear CE marking; meets European Union EMC Immunity Requirements (EN 50 082-1, 1992); RF radiated (IEC 801-3); ESD (IEC 801-2); EFT (IEC 801-4).

PHASING

To test two microphones and/or their cables for proper phasing, connect them to an amplifier and talk or sing into them while holding them three or four inches apart. The sound from the speakers should be the same when talking into either microphone or directly between them if they are in phase with each other. If the sound drops drastically, or if a dead spot is found when talking between the two microphones, either the microphones or their cables are out of phase. All cables and microphones should be tested in this manner to ensure that they are in phase with each other.

To change the phase of a low-impedance microphone cable, either use a Shure A15PRS Switchable Phase Reverser or interchange the wires connected to pins 2 and 3 of the connector. To change the phase of a microphone, the microphone cartridge leads must be interchanged (see Figure 4.) This should be performed by your dealer, the Shure Factory Service Department, or other qualified service personnel.

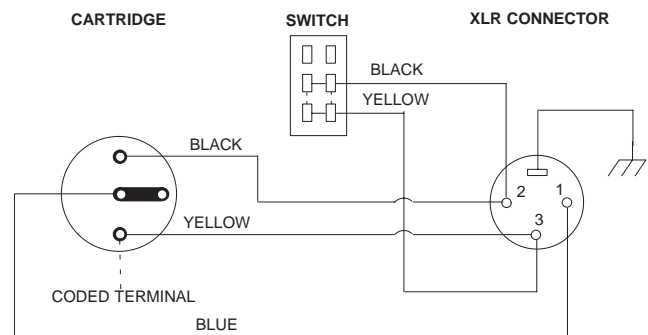

**INTERNAL CONNECTIONS
 FIGURE 4**

OPTIONAL ACCESSORIES

- Desk Stand S37A, S39A
- Line Matching Transformer A85F, A95UF
- Cable and Plug Assembly C25B, C25E, C25J

REPLACEMENT PARTS

- Cartridge R115
- On/Off Switch RK32S
- Plug Element RK169P